



MX Series

Milling and Turning centre

Performance
Technology
Power
Accuracy





MX *Series*

Powerful, Rapid, Accurate

Milling (M) and Mill/Turn (MT) centre

The MX multifunction machining centre is a high flexibility machine enabling machining operations in 5 axes and on 5 sides, in one setup part clamping, from roughing to finishing, as well as turning operations.

- 5 axis machining for workpiece up to 12.000 kg
- Hard material machining in a minimal time
- Very high accuracy in contouring and profiles
- Complete automation of the machine

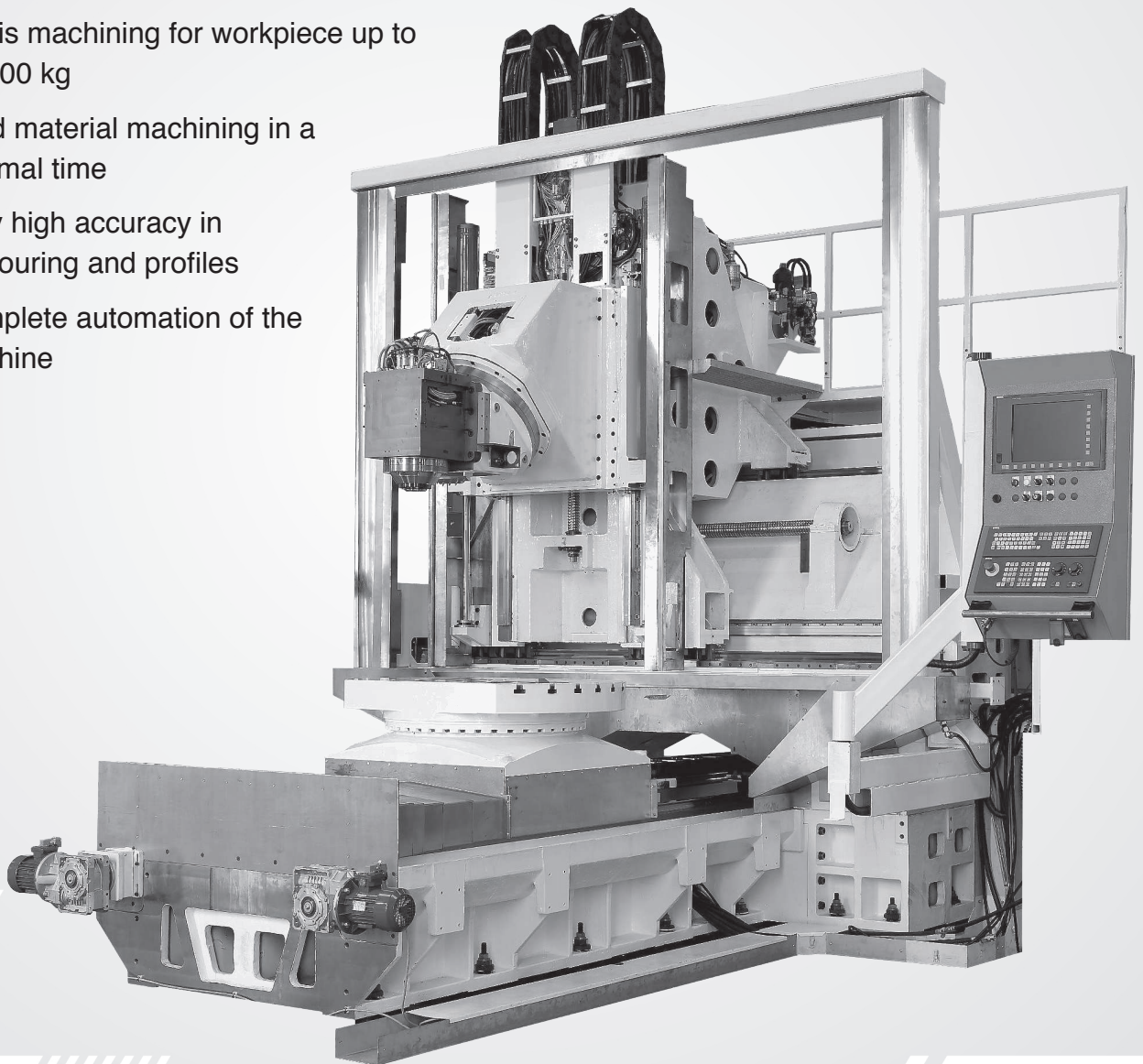



Structure :

Rigidity and Accuracy

- Structure with mobile column
- Cast iron with a high mechanical performance which maximises structure rigidity and allows optimum harmonic stability and maximum damping during demanding cutting conditions
- Machine secured on foundation with weight equally distributed over fixing points enabling extreme rigidity and a very high geometrical stability
- Modular design allows maximum flexibility in machine configuration to adapt to the technical requirements of customer
- Electrical cabinet fixed on the rear of the portal and protected IP54

Linear axes

- Ballscrew with integrated system of compensation for expansion
- Recirculating linear roller guide shoes ensuring minimum friction and efficient axis drive
- Automatic grease lubrication of linear roller guides minimising the pollution of coolant
- Absolute linear measurement by optical encoders in conformity with norm VDI/DGQ 3441

Head and Spindle

- Head equipped with integrated torque motor
- Head on a 45° plane allowing tilting from -45° up to +180°
- Spindle orientation : from vertical to horizontal, through all intermediate positions
- Powerful spindle with high torque allowing high metal removal rate
- Monitoring of the machining's vibrations to secure all the elements of the machine, the tool as well as the workpiece

Rotating table

- Table equipped with torque motor
- High rate of rotational and acceleration
- No backlash
- No wear
- Rigidity : high clamping torque enabling high power during roughing
- 2 versions : Milling and Mill/Turn

Numerical control

- Ergonomic design
- Very high capacity of memory and calculation
- Interactive programming
- Graphic simulation before machining for optimal safety

Environment - Ergonomics

- Chips evacuation channels with washing system and spiral conveyors
- Tool magazine outside of working area
- Complete safeguard ensuring a safety of the machine, the operator and the environment
- Very large accessibility to the table and the workpiece
- Tilting operator panel



MX Series

Universal head (A axis)

	M8 M/MT	MX 10/12 M/MT MX 12 ML MX 16/20
Rotating speed	100 rpm	100 rpm
Torque : working / clamping	1.410 / 2.500 Nm	1.750 / 2.500 Nm
Measuring on axes	Direct encoder	Direct encoder
Resolution	0,001°	0,001°
A axis clearance		
Spindle axis / saddle plane	+180° / -45°	
Spindle axis / table plane	-30° (left)	
	0° (vertical) -90° (horizontal right)	



Standard spindle

	MX 8 M	MX 8 MT MX 10/12 M/MT MX 12 ML MX 16/20
Taper	HSK 63A	HSK 100A
Rotating speed	100 - 18.000 rpm	100 - 10.000 rpm
Power (S6/S1)	30 / 20 kW	50 / 32 kW
Torque (S6/S1)	240 / 160 Nm	280 / 180 Nm
Characteristic speed	1.200 rpm	1.700 rpm



Equipments :

- Air wall for spindle protection
- Control captor for angular positioning of the spindle
- Electrospindle cooling system
- Mechanical clamping with spring rings
- Tool release with hydraulic control
- Greasing of bearings (MX 8 M : air/oil - Other models : grease)
- Taper cleaning by compressed air
- Vibration monitoring

Spindle alternatives (with universal or fork head)

MX 8/10/12/16/20 M - MX 12 ML (MX 8 only with universal head)	
12.000 rpm When fork head, clearance of B axis is limited from -105° up to +10°	
Taper	HSK 100A
Rotating speed	12.000 rpm
Power (S6/S1)	86 / 70 kW
Torque (S6/S1)	235 / 190 Nm
Characteristic speed	3.500 rpm

MX 10/12/16/20 M - MX 12 ML	
18.000 rpm When fork head, clearance of B axis is limited from -105° up to +10°	
Taper	HSK 63A
Rotating speed	18.000 rpm
Power (S6/S1)	30 / 20 kW
Torque (S6/S1)	160 / 240 Nm
Characteristic speed	1.200 rpm



Fork head / Alternative

MX 10/12 M

B axis clearance	-110° / +10°
Resolution	0,001°

with spindle 8.000 rpm

Taper	HSK 100A
Rotating speed	8.000 rpm
Power (S6/S1)	70 / 86 kW
Torque (S6/S1)	190 / 235 Nm
Characteristic speed	3.500 rpm

- B axis, parallel to the Y axis allows the evolution of the spindle around the horizontal axis
- The axis has a torque motor directly connected to the rotating parts ensuring a movement without backlash and a very accurate positioning

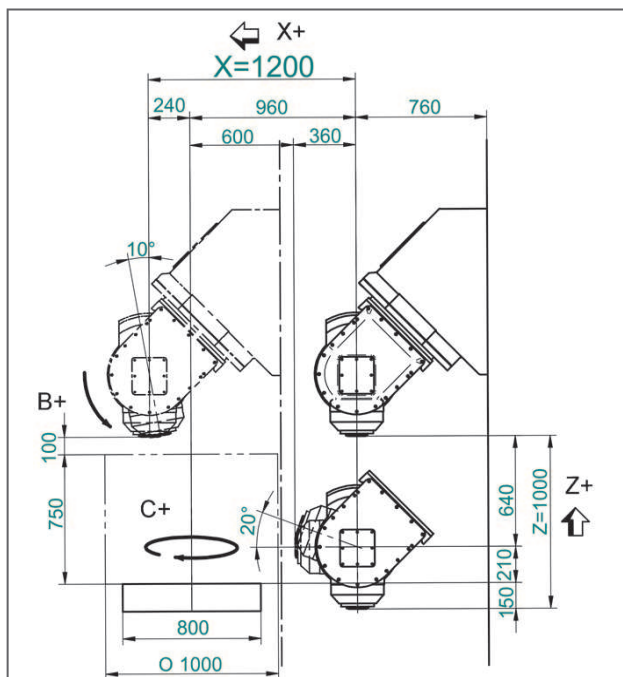
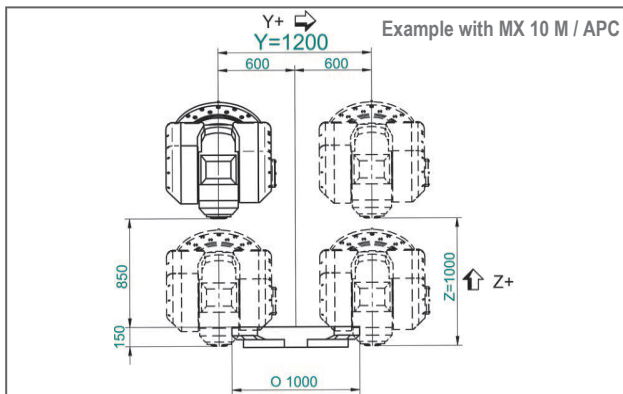

Mechanical head / Alternative

MX 10/12 M/MT/ML - MX 16/20 M

A axis clearance	-45° / +180°
Resolution	0,001°

with spindle 6.000 rpm

Taper	HSK 100A
Rotating speed	6.000 rpm
Power (S6/S1)	38 / 28 kW
Torque (S6/S1)	1.350 / 1.001 Nm
Characteristic speed	267 rpm

- Universal milling head with 1 rotating axis, on a 45° plane
- Very well suited for the hard material machining
- Allow an important roughing with an high chips removal rate

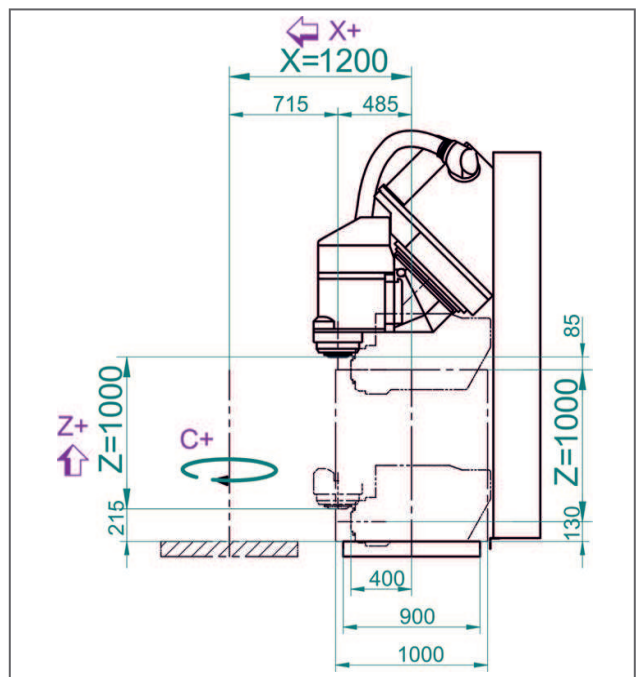
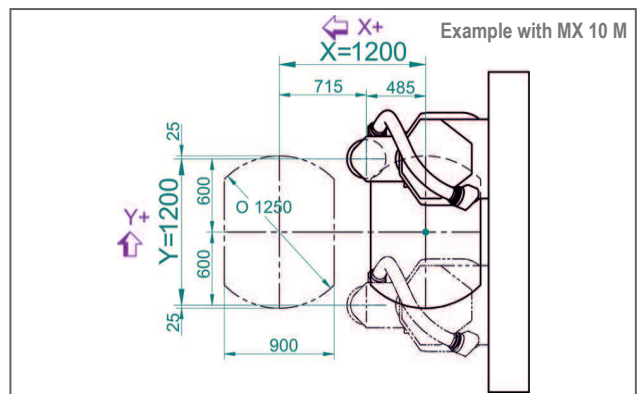

X travel limited to 1.075 mm with a workpiece Ø 1.250 mm



MX Series

Spindle diagrams : Power / Torque

18.000 rpm - 20 kW

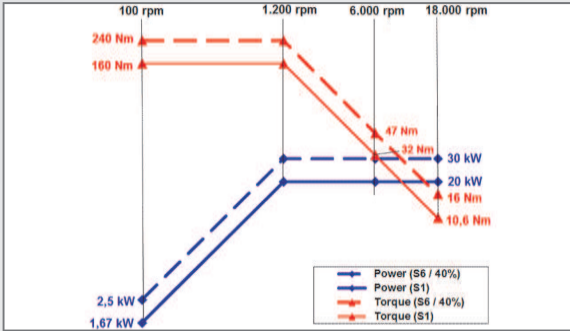

10.000 rpm - 32 kW

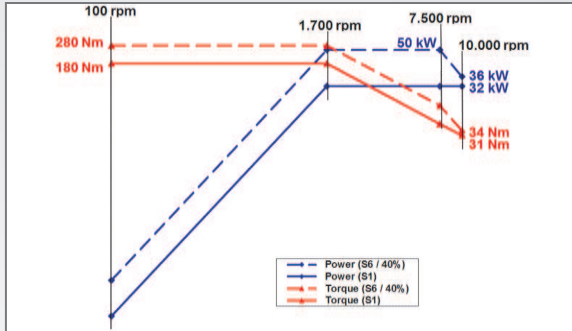

12.000 rpm - 70 kW

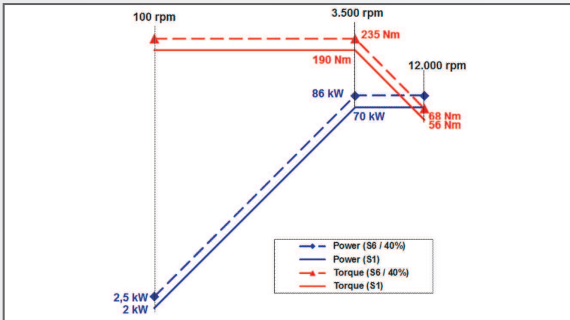

8.000 rpm - 70 kW / With fork head

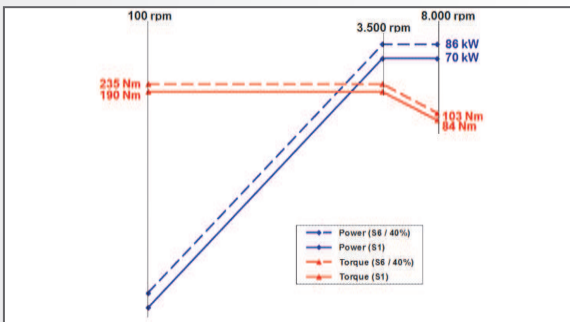

6.000 rpm - 28 kW / With mechanical head

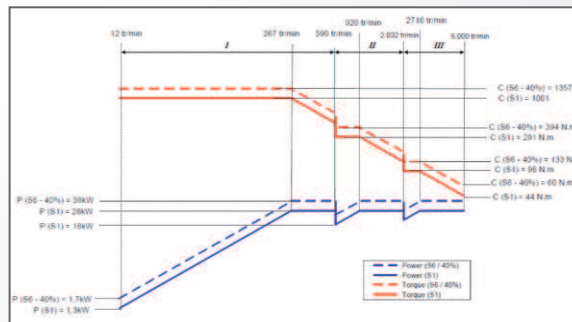



Tools changers

	MX 8 M	MX 8 MT MX 10/12 M/MT MX 12 ML
- Tool magazine is a chain type		
- Automatic load/unload of the tool is made in vertical position		
Pockets quantity	60	48
Taper	HSK 63A	HSK 100A
Tool dimension		
Max. Ø contiguous / non contiguous	95 / 120 mm	125 / 180 mm
Max. length	400 mm	400 mm
Max. weight : tool / in magazine	8 / 240 kg	15 / 360 kg
Tool changing time		
tool / tool - chip / chip	6 - 12 sec	6 - 12 sec



Alternatives : Tools changers

	MX 8/10/12 M MX 12 ML	MX 8 MT MX 10/12 M/MT MX 12 ML	MX 10/12 M/MT MX 12 ML
- Tool magazine is a chain or multi-chain type			Ideally suited for mechanical head
- Automatic load/unload is made in vertical position			
Housings quantity	120	96	48 / 96
Taper	HSK 63A	HSK 100A	HSK 100A
Tool dimension			
Max. Ø tool contiguous / non contiguous	95 / 120 mm	125 / 180 mm	250 mm
Max. length	400 mm	400 mm	500 mm
Max. tool weight	8 kg	15 kg	25 kg
Max. weight in magazine	480 kg	720 kg	kg
Tool changing time			
tool / tool - chip / chip	6 sec - 12 sec	6 sec - 12 sec	6 sec - 12 sec

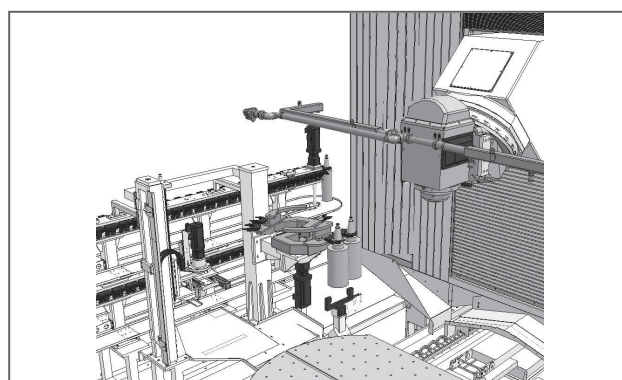
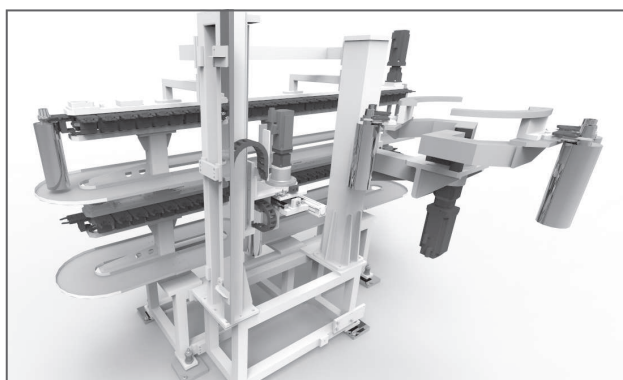



MX Series

The table

M version

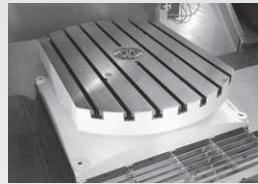

MT version

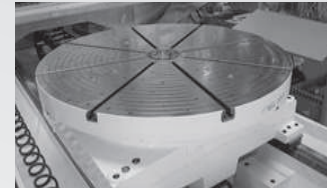

		Standard	Palletized (alternative)	Standard	Palletized (alternative)	
MX 8	Table dimension	mm	Ø 1.000 x 800	Ø 800 x 630	Ø 800	Ø 800
	Max. machining volume (ØxH)	mm	Ø 1.000 x 1.035 (*)	Ø 800 x 900 (*)	Ø 800 x 1.035 (*)	Ø 800 x 900 mm(*)
	Admissible load	kg	2.000	1.200	2.000	1.200 kg
	Rotating speed	rpm	50	50	500	500
	Torque : working / clamping	Nm	1.210 / 10.000	1.210 / 10.000	1.580 / 10.000	1.580 / 10.000
	Clamping system		7 slots 22H7	7 slots 22H7	8 radial slots	8 radial slots
	T slots	mm	H12 - 100 mm	H12 - 100 mm	22H7 / H12 - 45°	22H7 / H12 - 45°
	Central boring		Ø 63H7	Ø 63H7	Ø 63H7	Ø 63H7
MX 10	Table dimension	mm	Ø 1.250 x 900	Ø 1.000 x 800	Ø 1.000	Ø 1.000
	Max. machining volume (ØxH)	mm	Ø 1.250 x 1.130 (*)	Ø 1.200 x 1.000 (*)	Ø 1.250 x 1.130 (*)	Ø 1.200 x 1.000 (*)
	Admissible load	kg	2.500	1.500	2.000	1.500
	Rotating speed	rpm	65	65	500	500
	Torque : working / clamping	Nm	2.700 / 10.000	2.700 / 10.000	3.270 / 10.000	3.270 / 10.000
	Clamping system		7 slots 22H7	7 slots 22H7	8 radial slots	8 radial slots
	T slots	mm	H12 - 100 mm	H12 - 100 mm	22H7 / H12 - 45°	22H7 / H12 - 45°
	Central boring		Ø 63H7	Ø 63H7	Ø 63H7	Ø 63H7
MX 12	Table dimension	mm	Ø 1.600 x 1.250	Ø 1.400	Ø 1.400	Ø 1.400
	Max. machining volume (ØxH)	mm	Ø 1.600 x 1.130 (*)	Ø 1.600 x 1.000 (*)	1.600 x 1.130 (*)	1.600 x 1.000 (*)
	Admissible load	kg	4.000	2.500	4.000	2.500
	Rotating speed	rpm	50	50	250	250
	Torque : working / clamping	Nm	4.590 / 12.000	4.590 / 12.000	5.670 / 12.000	5.670 / 12.000
	Clamping system		10 slots 22H7	10 slots 22H7	8 radial slots	8 radial slots
	T slots	mm	H12 - 125 mm	H12 - 125 mm	22H7 / H12 - 45°	22H7 / H12 - 45°
	Central boring		Ø 100H7	100H7	Ø 100H7	100H7

(*) with restriction on X travel



L version

MX 12 ML

MX 12	Travels	X 2.000 mm Y 1.600 mm Z 1.000 mm
	Table dimension	Ø 1.600 x 1.250 mm
	Max. machining volume (ØxH)	1.600 x 1.130 mm (*)
	Admissible load	4.000 kg
	Rotating speed	50 rpm
	Torque : working / clamping	4.590 / 12.000 Nm
	Clamping system	10 slots
	T slots	22H7 / H12 - 125 mm
Central boring	Ø 100H7	



Interference diagrams with standard table

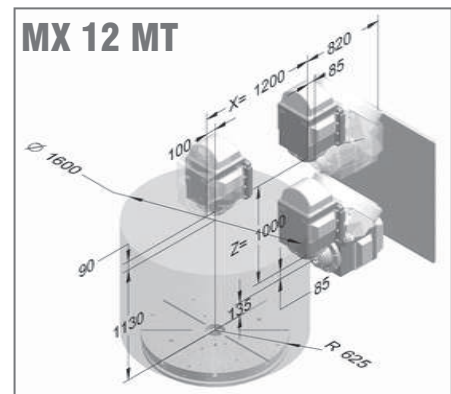
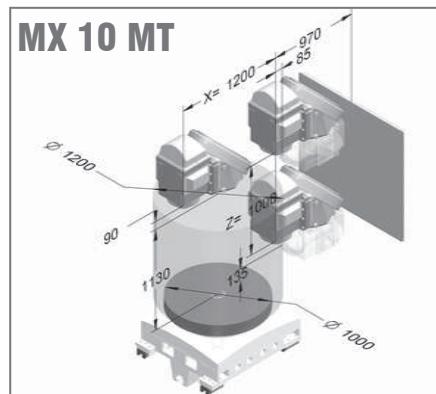
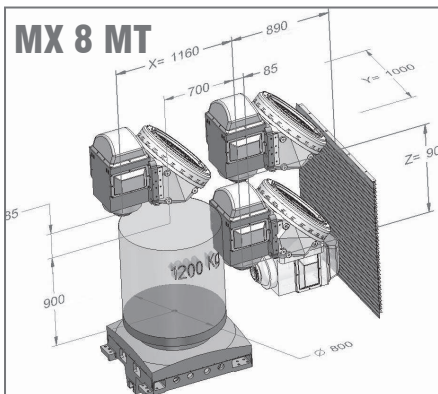
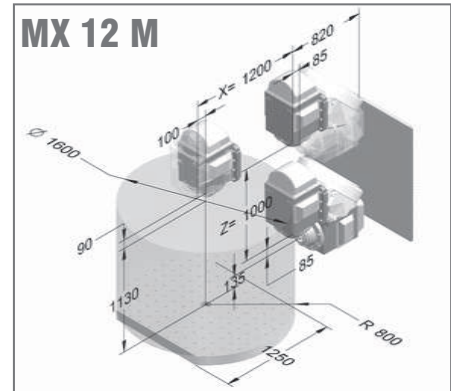
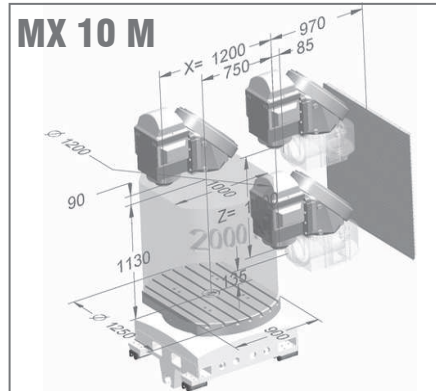
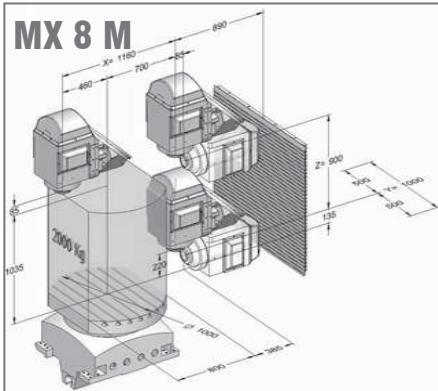

Interference diagrams with palletized table

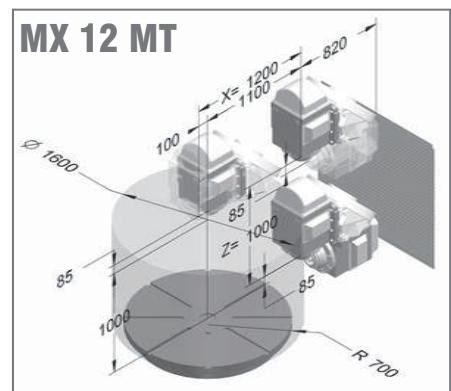
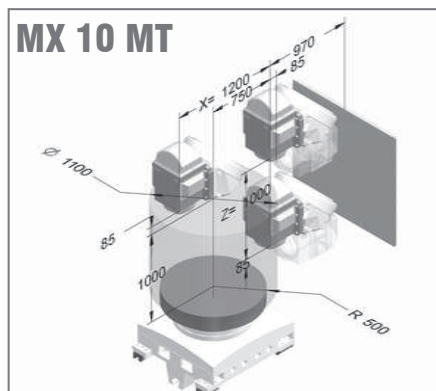
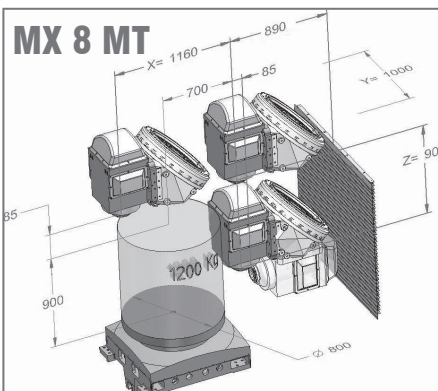
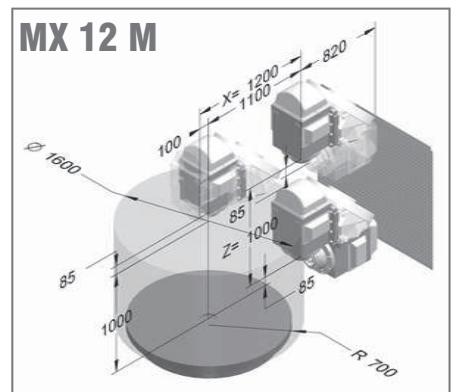
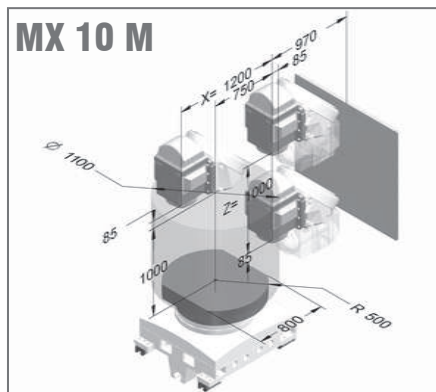
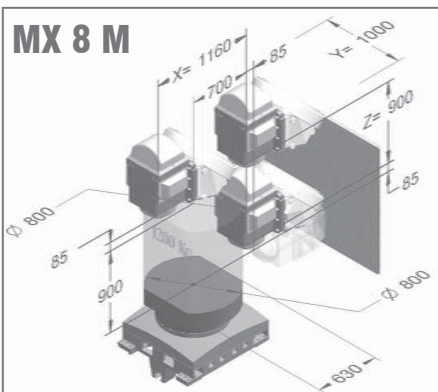



MX Series

Extension of the range - MX 16, MX 20

In order to allow our customers to machine extremely large parts, the MX range has been extended to include extra-large models, with MX 16 and MX 20.

The larger workpiece clearance will be appreciated by some of our customers, particularly in the aeronautic and energy industries.

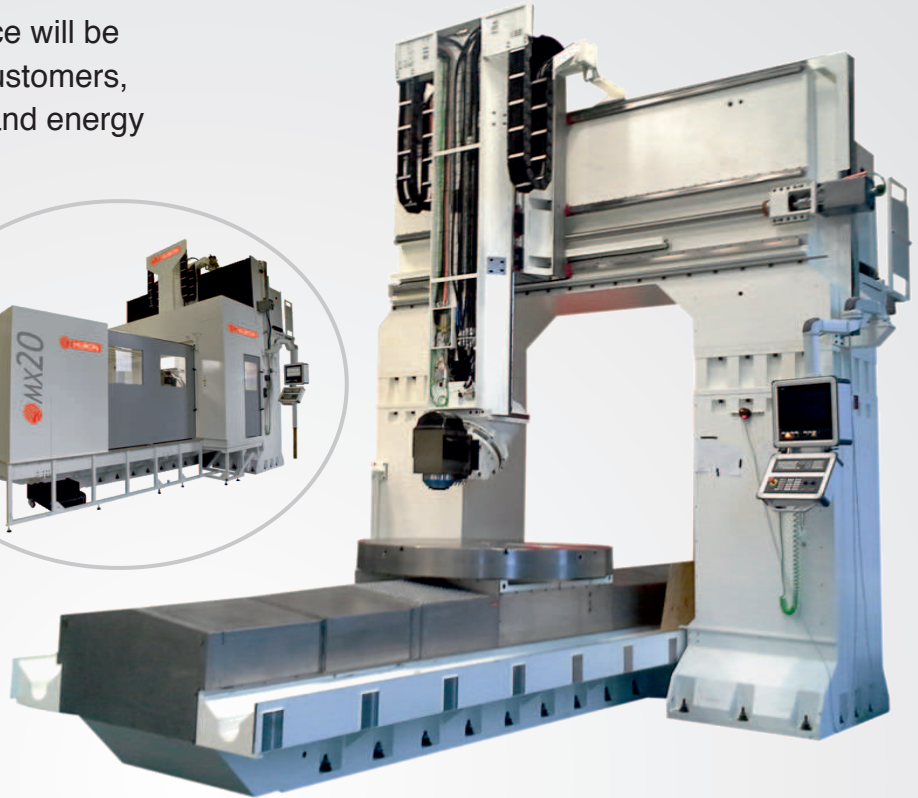
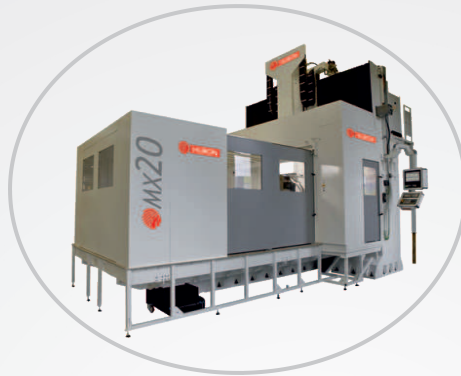

Heads and spindls

Offer identical to other machines in the range

Tool changers

Automatic loading/unloading of tools is made in vertical position

	Standard	Alternatives			
Qty of housings	40	60	60	100	100
Type	Chain	Chain	Chain	Chain	Chain
Taper	HSK 100-A	HSK 63-A	HSK 100-A	HSK 63-A	HSK 100-A
Tool dimension					
Max. Ø tool	120 mm	90 mm	120 mm	90 mm	120 mm
Max. length	300 mm	400 mm	400 mm	400 mm	400 mm
Max. weight of tool	10 kg	8 kg	10 kg	8 kg	25 kg
Max. weight in magazine	200 kg	240 kg	300 kg	400 kg	kg
Tool changing time					
tool/tool - chip/chip	6 - 16 sec	6 - 20 sec	6 - 20 sec	6 - 20 sec	5 - 20 sec



The table - M version

		MX 16 M	MX 20 M
Table dimension	mm	Ø 1.750	Ø 2.200
Max. machining volume (ØxH)	mm	Ø 2.000 x 1.300	Ø 2.500 x 1.650
Admissible load	kg	10.000	12.000
Distance between column	mm	2.000	2.500
Rotating speed (S6)	rpm	9	7
Torque : Working (S6) / Clamping	Nm	12.000 / 35.000	18.000 / 38.000
Clamping type	mm	8 T slots 22H12 - 100 mm	8 T slots 22H12 - 100 mm
Central boring		Ø 100H7	Ø 100H7

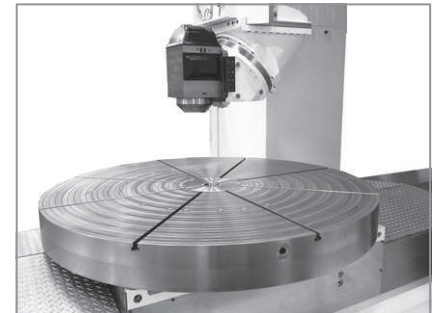

MX 16 M - Head/table positioning

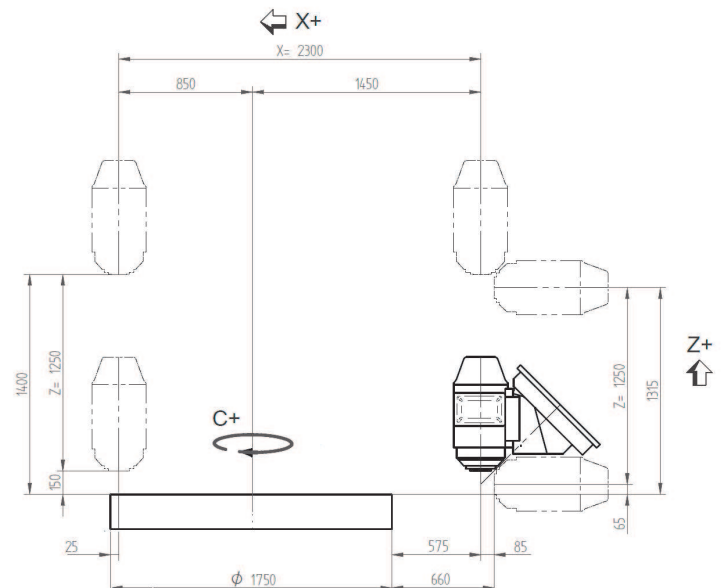
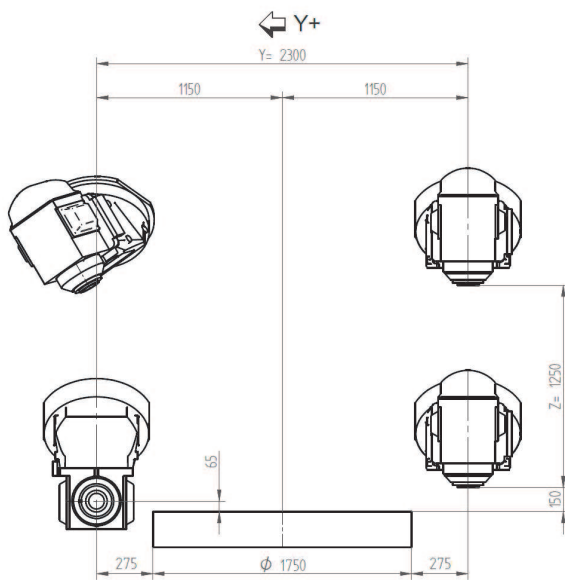

MX 20 M - Head/table positioning

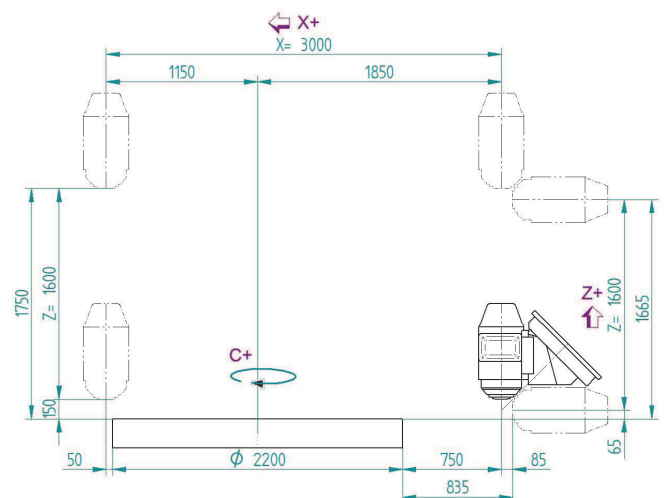
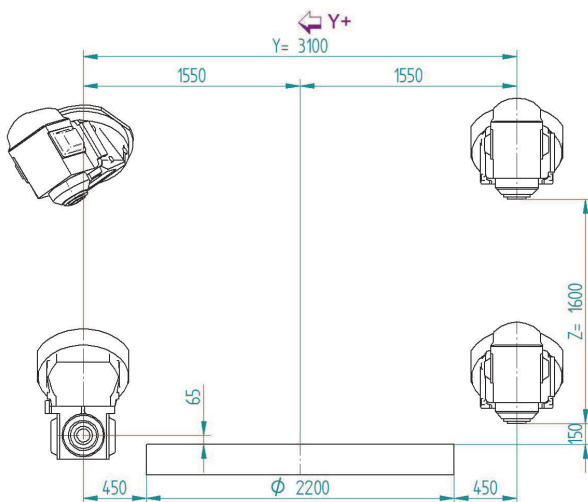



MX Series

Automation

For higher productivity, increase production speeds and optimise machining cycles, we offer a variety of palletizing configurations. The processes are independent, safe and reliable.

- Palletizer attached to the front of the machine
- Optimal operator access to the machine
- Constant visibility over the working area
- Safeguard for easy, ergonomic pallet loading/unloading from above and from the front of the machine

Twin-pallet device
for MX 8 to MX 12

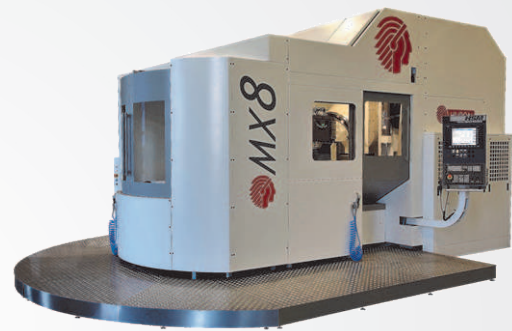
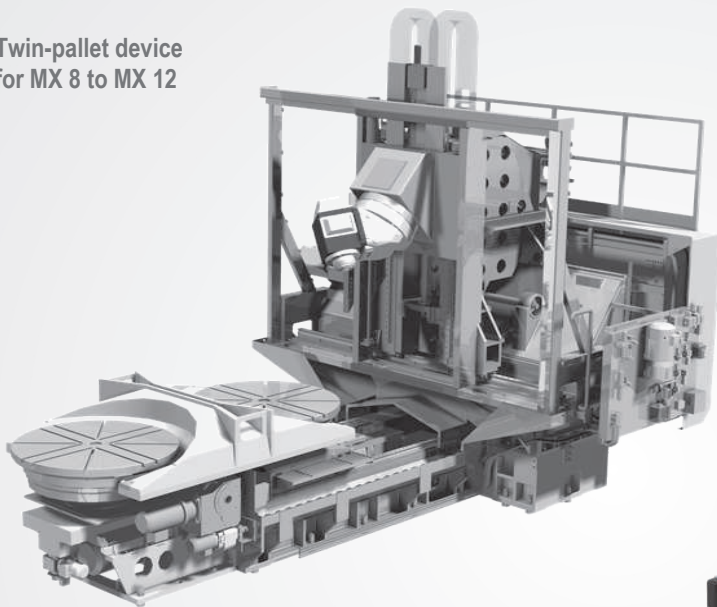

Pallet device with up to 4 pallets
for MX 16 and MX 20

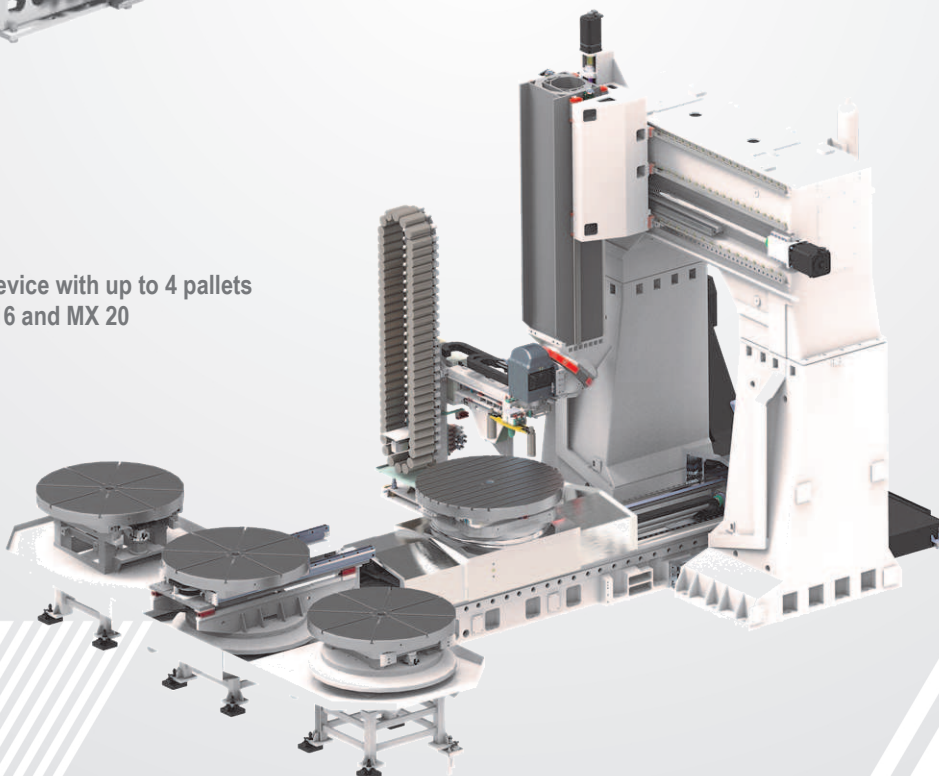



Cycles CN HURON

PRECILIFE or how to manage tool life automatically ? (*)

This cycle provides automatic tool checking during machining or at tool change. If critical wear or a broken tool is detected, the system automatically triggers the replacement of the tool at the most appropriate time. It therefore safeguards the integrity of the workpiece and the cutting tools and optimizes tool use. The profitability of the machine is increased by reducing downtime and tooling costs.

MAIN FEATURES

- Automated tool measurement, inspection and replacement done in the machining process
- No change to the NC program
- Implemented by HURON
- Configurable wear and breakage detection tolerance for each tool
- Automatic replacement of tools

(*) Only with 3 axes machines, spindle in vertical position

PRECIPOWER or how to optimise roughing operations ?

It takes care of optimizing the roughing operation by automatically modulating and adapting the feedrate, in real time, to the value that result in peak material removal.

MAIN FEATURES

- Full use of available spindle power
- Automatic feedrate modulation
- Maximize material removal rate
- Spindle and rotating axes overload protection during roughing

PRECIFIVE or how to get an accurate and automatic calibration of the machine kinematic ?

Automate the calibration of the kinematics by carrying out the measurement of the position and the orientation of the rotation axes.

The calibration can be executed directly in an NC program to ensure optimum accuracy during critical machining operations.

MAIN FEATURES

- Quick, accurate, repeatable measuring system
- Optimized machining accuracy
- Compensation of the thermal expansion of the machine
- Reduces rejected parts
- Rapid evaluation following a machine collision
- Control report

PRECIPROTECT or how to save time while protecting the machine and the workpieces ?

This cycle allows real-time monitoring of toolpaths and machine movements in order to anticipate any form of collision. The machine and the part are thus preserved.

MAIN FEATURES

- Conserve machine accuracy
- Save time : no simulation required, control is done in real-time
- Save money : No more repair or machine stop due to a collision
- Increase profitability : preserve integrity of the machine and workpiece ; no more delivery delays to customers
- Reliability : detection of an imminent collision triggers an immediate and automatic stop of the movements of the machine
- Peace of mind : let the machine work unsupervised



MX Series

Technical characteristics

Linear axes X / Y / Z		MX 8 M	MX 8 MT	MX 10 M	MX 10 MT	MX 12 M	MX 12 MT
Travels	mm	1.160 x 1.000 x 900		1.200 x 1.200 x 1.000		1.200 x 1.600 x 1.000	
Rapid feedrates	m/min	40		40		40	
Acceleration per axis	m/s ²	4		4		4	
Rotating A axis - Universal head		MX 8		MX 10		MX 12	
Rotating speed	rpm	100		100		100	
Torque : Work / Clamping	Nm	1.410 / 2.500		1.750 / 2.500		1.750 / 2.500	
Rotating C axis - Table		MX 8 M	MX 8 MT	MX 10 M	MX 10 MT	MX 12 M	MX 12 MT
Rotating speed	rpm	50	500	65	500	50	250
Table dimension	mm	1.000 x 800	Ø 800	1.250 x 900	Ø 1.000	1.600 x 1.250	Ø 1.400
Admissible load	kg	2.000	2.000	2.500	2.500	4.000	4.000
Spindle		MX 8 M		MX 8 MT - MX 10/12 M/MT			
Spindle rotation	rpm	18.000		10.000			
Taper		HSK 63A		HSK 100A			
Power - Torque (S6/S1)	kW - Nm	30 / 20 - 240 / 160		50 / 32 - 280 / 180			
Characteristic speed	rpm	1.200		1.700			
Accuracies (VDI DGQ 3441)							
Uncertainty : P		Linear axes : 7 µ - Rotating axes : 10 sec					
Repeatability : Ps medium		Linear axes : 4 µ - Rotating axes : 5 sec					
Tools magazines		MX 8 M		MX 8 MT - MX 10/12 M/MT			
Qty of housings		60		48			
Taper		HSK 63A		HSK 100A			
Tool dimension :	mm	400 - 95		400 - 125			
Length - Ø - Weight	kg	8		15			
Coolant		MX 8 M		MX 8 MT - MX 10/12 M/MT			
Flow - Pressure	l/min - bar	30 - 5		60 - 5			
Tank	litres	700		1.500			

Alternatives

Travels		MX 12 ML					
Travels	mm	2.000 x 1.600 x 1.000					
Rotating A axis - Head		Fork head			Mechanical head		
Swivelling angle		-110° / +10°			-0° / 180°		
Spindles		MX 8/10/12/16/20 M			MX 10/12/16/20 M		
Rotating speed	rpm	12.000			18.000		
Taper		HSK 63A			HSK 100A		
Power - Torque (S6/S1)	kW - Nm	86 / 70 - 235 / 190			30 / 20 - 240 / 160		
Characteristic speed	rpm	3.500			1.200		
Rotating C axis - Palletized table		MX 8 M	MX 8 MT	MX 10 M	MX 10 MT	MX 12 M	MX 12 MT
Rotating speed	rpm	50	500	65	500	50	250
Dimension	mm	800 x 630	Ø 800	1.000 x 800	Ø 1.000	Ø 1.400	Ø 1.400
Admissible load	kg	1.200	1.200	1.500	1.500	2.500	2.500
Tools magazines		MX 8/10/12		MX 8/10/12		MX 10/12	
Qty of housings		120		96		48 / 96	
Taper		HSK 63-A		HSK 100-A		HSK 100-A	
Tool dimension :	mm - mm	400 - 95		400 - 125		500 - 250	
Length - Ø - Weight	kg	8		15		25	



Technical characteristics

Linear axes X / Y / Z		MX 16 M	MX 20 M
Travels	mm	2.300 x 2.300 x 1.250	3.000 x 3.100 x 1.500
Rapid feedrates	m/min	40	20
Acceleration per axis	m/s ²	X / Y / Z = 3	X = 1,8 - Y / Z = 2
Rotating A axis - Universal head		MX 16 M	MX 20 M
Rotating speed	rpm	100	100
Torque : Work / Clamping	Nm	1.410 / 2.500	1.410 / 2.500
Rotating C axis - Table		MX 16 M	MX 20 M
Rotating speed	rpm	9	7
Table dimension	mm	Ø 1.750	Ø 2.200
Admissible load	kg	10.000	12.000
Spindle		MX 16 M	MX 20 M
Spindle rotation	rpm	10.000	
Taper		HSK 100A	
Power - Torque (S6/S1)	kW - Nm	50 / 32 - 280 / 180	
Characteristic speed	rpm	1.700	
Accuracies (VDI DGQ 3441)			
Uncertainty : P		Linear axes : 7 µ - Rotating axes : 10 sec	
Repeatability : Ps medium		Linear axes : 4 µ - Rotating axes : 5 sec	
Tools magazines		MX 16 M	MX 20 M
Qty of housings		40	
Taper		HSK 100A	
Tool dimension :	mm	300 - 120	
Length - Ø - Weight	kg	10	
Coolant		MX 16 M	MX 20 M
Flow - Pressure	l/min - bar	30 - 5	30 - 5
Tank	litres	1.500	1.500

Optional equipments

Various spindles - Various tools changers - Pallet device - High pressure coolant 70 bar - Microspraying coolant - Air blast - Workpiece probe - Tool probe - Oil extraction device - Oil skimmer - Sight glass - Air conditioning of electrical cabinet - Pressurization of measuring scales

Over-all measurements

Standard machine		MX 8 M/MT	MX 10 M/MT	MX 12 M/MT	MX 12 L	MX 16 M	MX 20 M
Width	mm	6.180	6.335	6.405	6.405	8.000	8.500
Length	mm	5.800	7.950	8.360	8.770	9.000	10.350
Height	mm	3.760	4.380	4.800	4.800	6.570	6.750
Weight of the machine	kg	22.000	35.000	35.000	45.000	45.000	90.000
Machine with pallet device		MX 8 M/MT	MX 10 M/MT	MX 12 M/MT		MX 16 M	MX 20 M
Width	mm	6.250	5.800	6.124			
Length	mm	7.450	10.000	10.240			
Height	mm	3.850	4.800	4.800			
Weight of the machine	kg	25.000	40.000	43.000			

... is coming soon ...



INDIA

Jyoti CNC Automation Ltd
G-506 & 2839, Lodhika, G.I.D.C.,
Vill. Metoda,
Dist: Rajkot - 360 021
☎ +91-2827 287081/082
✉ info@jyoti.co.in

FRANCE

Huron Graffenstaden SAS
156 route de Lyon
BP 30030
67401 Illkirch Graffenstaden Cedex
☎ +33 (0)3 88 67 52 52
☎ +33 (0)3 88 67 69 00
✉ commercial@huron.fr

CANADA

Huron Canada
85 rue St-Charles Ouest #105
Longueuil, Québec, J4H 1C5
☎ +1 514 448 4873
☎ +1 514 448 4875
✉ infocanada@huron.fr

GERMANY

Huron Fräsmaschinen GmbH
Siemensstrasse 56
70839 Gerlingen
☎ +49 (0)7156 92836 12
☎ +49 (0)7156 92836 50
✉ verkauf@huron.de

TURKEY

Huron Graffenstaden Türkiye İrtibat bürosu
Businnes Istanbul B Blok Kat:1/10
Merdivenköy Mah. Dikyo Sok. No:2
34732 Kadıköy - Istanbul
☎ +90 (0)216 463 33 67
✉ info-turquie@huron.fr